



MOTORS 9.9HP - 20HP

Install Guide for Motors 9.9HP - 20 HP
WB.9.9-20M.02

ATTENTION

Confirm with the Mercury Marine Installation manual supplied with the motor, the correct lifting device required prior to hoisting the motor. Ensure proper mounting template is used based on Boat Model.

TOOLS REQUIRED



Safety Glasses

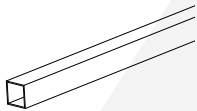

Motor Mount Spacer

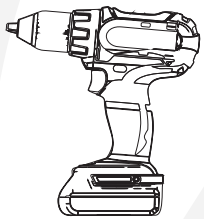

Drill



Impact Wrench

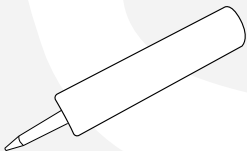

Silicone

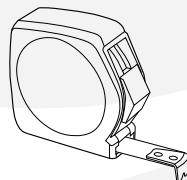

Tape Measure

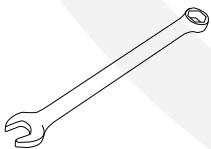

7/16" Wrench
1/2" Wrench
9/16" Wrench

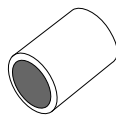

1/2" Impact Socket

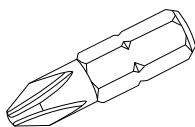

#3 Phillips Bit

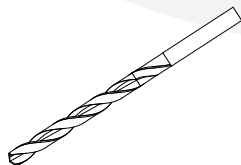

5/16" Drill Bit





MOTORS 9.9HP - 20HP

Install Guide for Motors 9.9HP - 20 HP
WB.9.9-20M.02

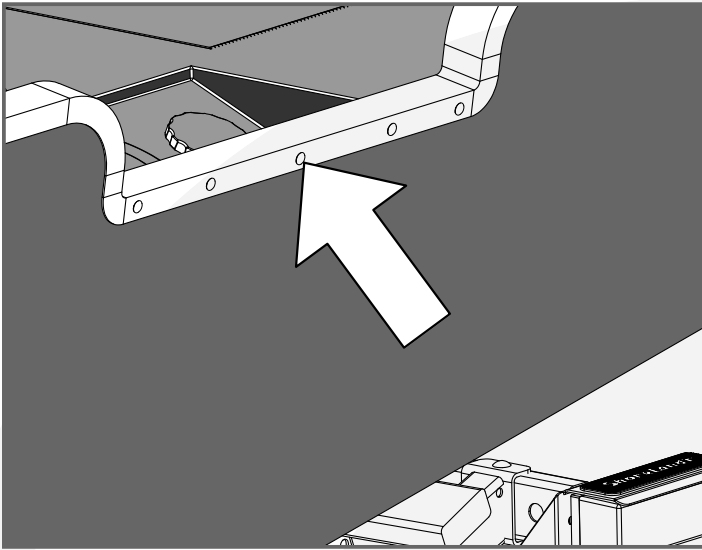

STEP 1

Riveted hulls may require a screw on the transom cap to be removed for properly mounting the motor.

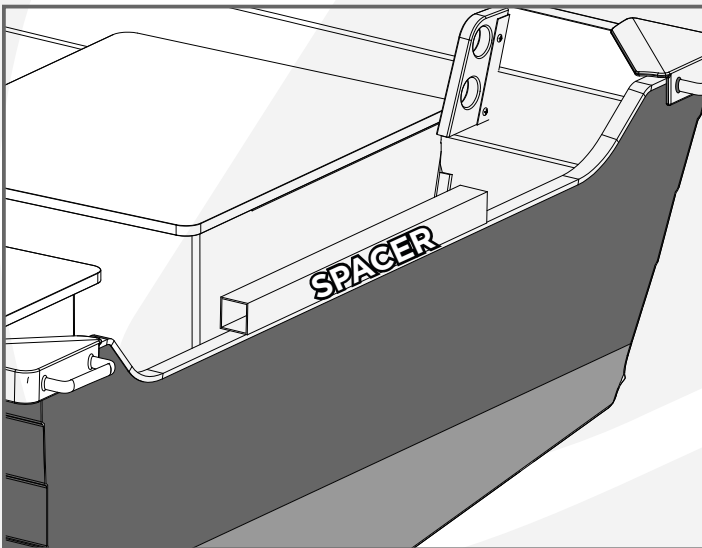

STEP 2

Locate and mount the motor mounting spacer onto the hull of the boat.



STEP 3

Review Motor Crate to locate any damage or potential issues with the Motor. Uncrate Motor and review again for any damages.

ATTENTION

If there is damage to the Motor or Crate, review with Lead Rigger/Shop Foreman.



MOTORS 9.9HP - 20HP

Install Guide for Motors 9.9HP - 20 HP
WB.9.9-20M.02



STEP 4

Refer to the Mercury Marine installation manual included with the Motor for installing the motor.

Confirm with the Mercury Marine Installation manual the correct lifting device required prior to lifting the motor.



QR Code directs to Mercury Owners manuals. Continue to Americas - United States site for reference documents when prompted.

ATTENTION

Do not drill pilot holes prior to confirming motor location with Lead Rigger/Shop Foreman.

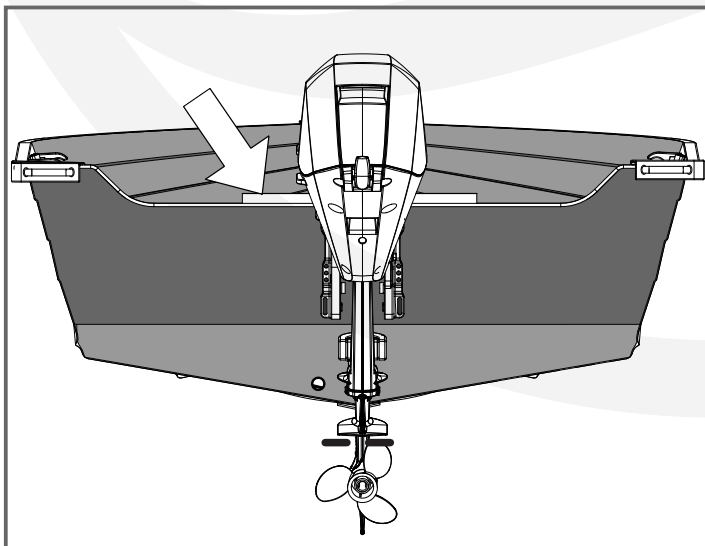

STEP 5

Once the motor has been installed according to the Mercury Marine installation manual, remove the mounting spacer.

ATTENTION

Motors 9.9-20HP require a 5/16" gas line for installation.