



20HP ELH-PT MOTOR

Motor Install Guide
WB.20ELHPTM.02

ATTENTION

Confirm with the Mercury Marine Installation manual supplied with the motor, the correct lifting device required prior to hoisting the motor. Ensure proper mounting template is used based on Boat Model.

TOOLS REQUIRED



Safety Glasses

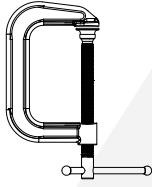

C-Clamp

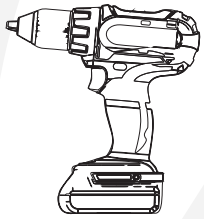

Drill



Impact Wrench

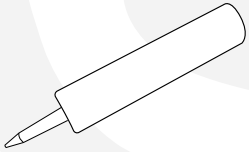

Silicone

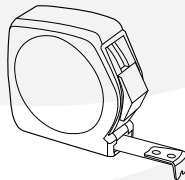

Tape Measure

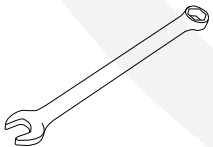

7/16" Wrench
1/2" Wrench
9/16" Wrench

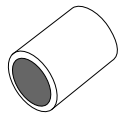

1/2" Impact Socket

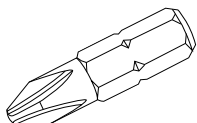

#3 Phillips Bit

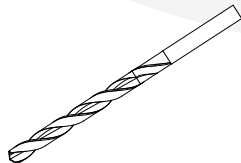

5/16" Drill Bit





20HP ELH-PT MOTOR

Motor Install Guide
WB.20ELHPTM.02

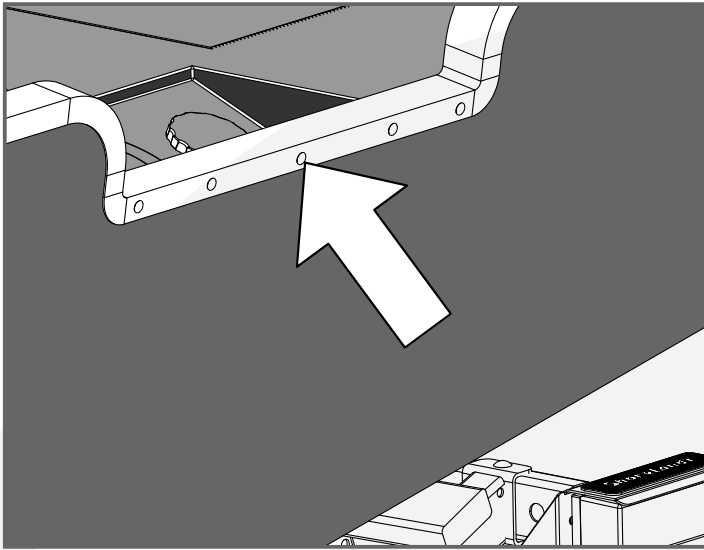

STEP 1

Riveted hulls may require a screw on the transom cap to be removed for properly mounting the motor.

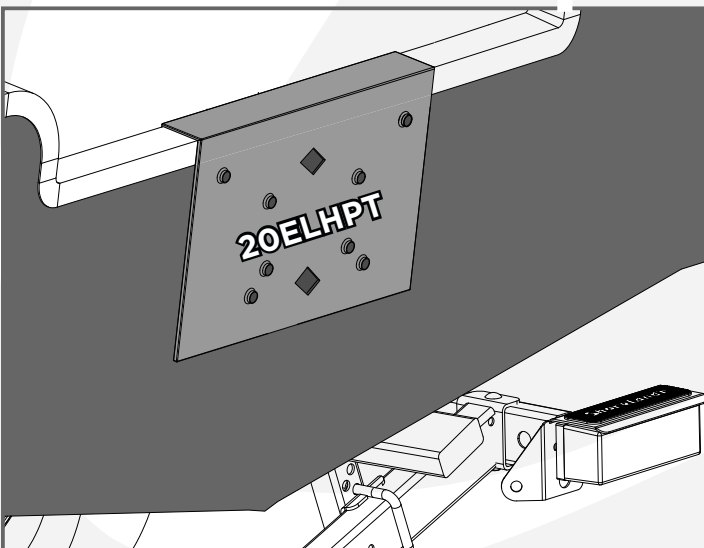

STEP 2

Mount the 20ELHPT Motor Template onto the Transom of the Boat

NOTE

Ensure the proper Motor Template labelled 20ELHPT is sitting flush with the Transom.

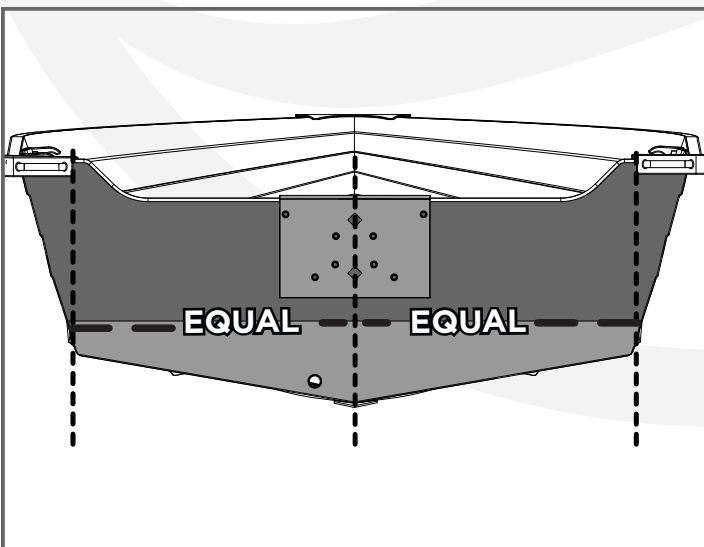

STEP 3

Align the center of the template with the center of the boat and clamp in place.

Confirm template location with Lead Rigger/Shop Foreman.

ATTENTION

Do not drill pilot holes prior to confirming template location with Lead Rigger/Shop Foreman.



20HP ELH-PT MOTOR

Motor Install Guide
WB.20ELHPTM.02

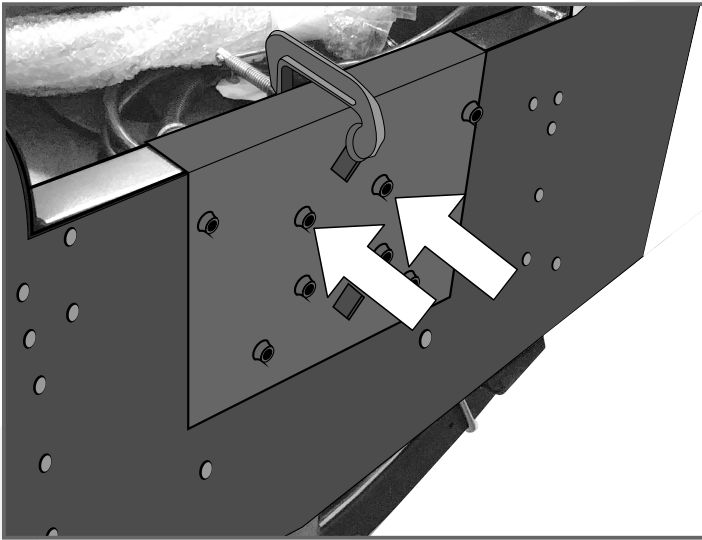

STEP 4

Using the 5/16" drill bit, drill through the Transom into the marked holes of the Motor Template.

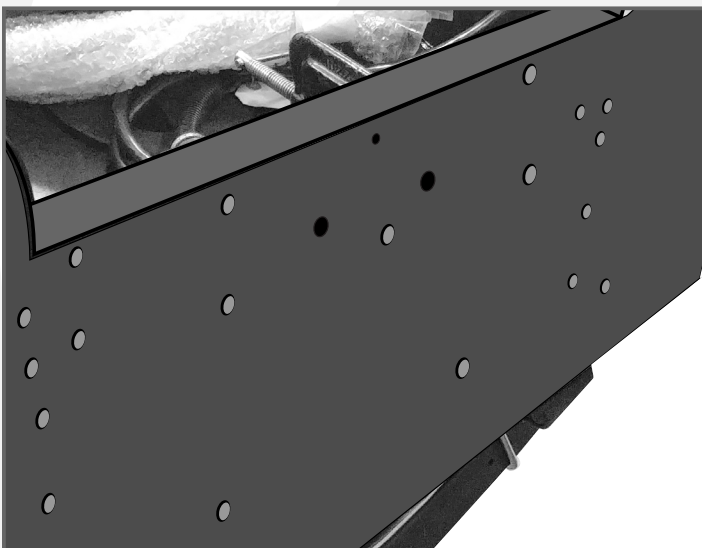

STEP 5

Remove the Motor Template from the Transom.



STEP 6

Review Motor Crate to locate any damage or potential issues with the Motor. Uncrate Motor and review again for any damages.

ATTENTION

If there is damage to the Motor or Crate, review with Lead Rigger/Shop Foreman.



20HP ELH-PT MOTOR

Motor Install Guide
WB.20ELHPTM.02



STEP 7

Refer to the Mercury Marine Installation manual included with the Motor for installing the motor.

Confirm with the Mercury Marine Installation manual the correct lifting device required prior to lifting the motor.



QR Code directs to Mercury Owners manuals. Continue to Americas - United States site for reference documents when prompted.

ATTENTION

This motor requires a 5/16" gas line for installation.